

## Self Closing Sanitary Yard Hydrant Operation and Maintenance Instructions

### OPERATION AND MAINTENANCE

#### 1.) **Packing Nut Leak**

Hydrant is designed to use clean water at 20 psi to 100 psi. Should leakage occur at packing nut, simply tighten nut until leakage stops. If tightening nut does not stop leakage, remove nut and replace packing. Figure 3

#### 2.) **To Change Seal, O-ring**

- Remove Pivot Bolt and loosen packing nut (Figure 5)
- Lift out operating rod and change o-ring seal on tip.
- Replace operating rod and Pivot Bolt, tighten packing nut.
- Adjust handle.

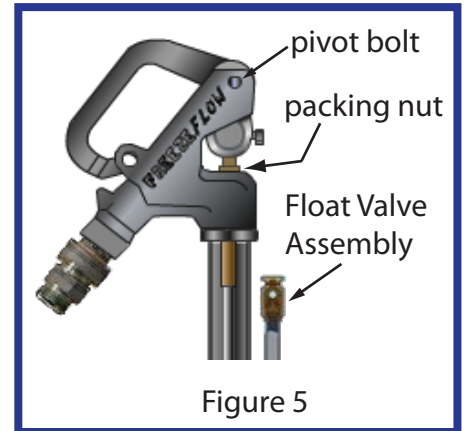

Figure 5

#### 3.) **Leakage from float valve**

Leakage from float valve is typically due to not flushing supply lines properly.

- To clean, unscrew Hex Cap from round base.
- Remove ball and o-ring.
- Replace ball and o-ring after cleaning.
- Reassemble Float Valve.

#### 4.) **ADA Handle Operating Rod Adjustment**

Adjust operating rod by doing the following: Figure 6

- Turn off water supply
  - Loosen square set screw
  - Lift handle to slide connector up brass operating rod
  - Hand tighten square set screw so it will drag across brass rod extension when handle is lowered.
  - Lower handle until approximately 3 inches before handle completely closes.
  - Tighten set screw 3 inches before handle completely closes.
  - Perform leak test according to item #5 in Installation above. Hydrant operating rod is properly adjusted when no leaks are detected from outlet.
- 5.) To prevent unauthorized use, hydrant handle can be padlocked to head casting using locator holes provided.
- 6.) NOTE: If the hydrant has not been used for a long period of time, it is advisable to flush the hydrant for 60 seconds when the water is used for drinking.

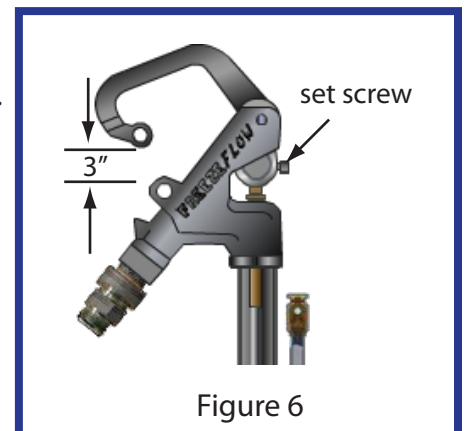

Figure 6